

A2S

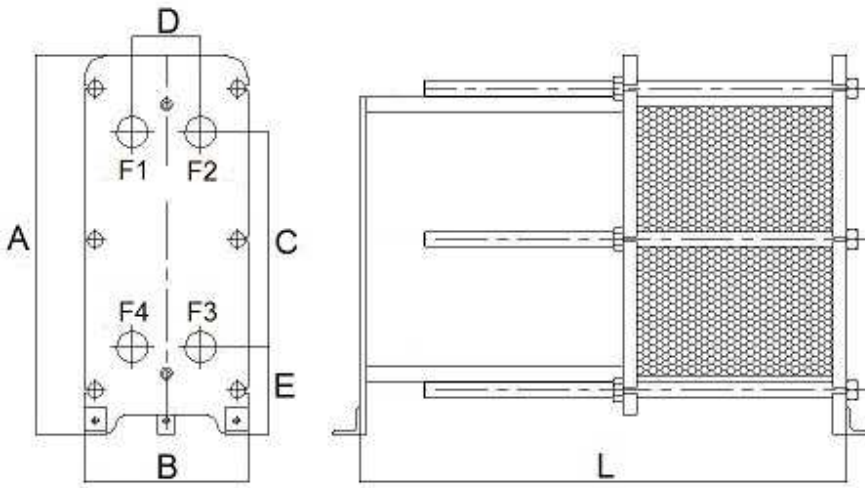

Scambiatori di calore a piastre ispezionabili
Gasketed plate heat exchangers



Conessioni Connections			
Lato caldo Hot side		Lato freddo Cold side	
Entrata Inlet	Uscita Outlet	Entrata Inlet	Uscita Outlet
F1	F4	F3	F2

Superficie Piastra Plate surface area	Diametro attacchi Connections size	Quota di serraggio Tightening measure	Volume canale Channel volume
m ²		mm	dm ³
0,073	2" gas M	Np x 2,90 (±0,5)	0,1976

Pressione max esercizio Max working pressure	A	B	C	D	E	L	Numero piastre Number of plates	Peso piastra Plate weight	Peso telaio Frame weight
bar	mm							kg	kg
PN10	596	300	394	126	130	328	Np≤60	0,41	57
						528	61<96		60
						728	97<132		63
						1028	133<195		67
PN16	596	300	394	126	130	333	Np≤60	0,49	70
						533	61<96		74
						733	97<132		78
						1033	133<195		82

Componenti Components	Esecuzione standard Standard version	Esecuzione su richiesta Version on request
Piastre Plates	Acciaio inox aisi 304/316 Stainless steel 304/316	Titanio Titanium
Guarnizioni Gaskets	NBR HT (max 120°C) EPDM HT (max 150°C)	FKM (max 180°C)
Telaio Frame	Acciaio al carbonio verniciato Painted carbon steel	Acciaio inox aisi 304 Stainless steel 304